



1.2 米跌落测试报告

1.2m Drop Test Report

Sample Description
& Model

LITHIUM ION BATTERY VP98652

Applicant

VAPEX TECHNOLOGY LTD

Manufacturer

Shenzhen EPT Battery Co., Ltd



P O N Y 谱尼测试
Pony Testing International Group

www.ponytest.com



微信扫一扫，使用小程序 小程序扫一扫，在线验证
No.: MNI7TVFX90185746
Code: edl60s



Pony Testing International Group

I. SAMPLE DESCRIPTION

Sample Description	LITHIUM ION BATTERY	Sample Model	VP98652
Applicant	VAPEX TECHNOLOGY LTD		
Manufacturer	Shenzhen EPT Battery Co., Ltd		
Nominal Voltage	7.6V	Rated Capacity	8.0Ah
Outer package	Carton	Inner package	Paper Box
Dimensions	335×175×180mm	Cushion	Paperboard
Gross weight	8.00kg	Battery number	20Pcs/packing
Entrust date	2019-03-28	Finished date	2019-04-01
Packaging type	Package including lithium batteries.		

II. TEST METHOD

UNITED NATIONS "Recommendations on the TRANSPORT OF DANGEROUS GOODS"
Model Regulations (ST/SG/AC.10/1/Rev.20), Chapter 3.3 special provisions 188.

III. TEST ITEM

1.2m Drop test
Gross Weight Measure

IV. CONCLUSION

This package is capable of withstanding a 1.2m drop test in any orientation without damage to cells or batteries contained therein, without shifting of the contents so as to allow battery to battery contact and without release of contents. The weight of the package is 8.00kg gross mass.

Appraiser: Zhou Xiang Zhu Checker: Jinshifang

Approver: Yishawbn

Issue Date: April 1, 2019



Pony Testing International Group

V. STANDARD REQUIREMENT

UNITED NATIONS "Recommendations on the TRANSPORT OF DANGEROUS GOODS"
Model Regulations (ST/SG/AC.10/1/Rev.20), Chapter 3.3 special provisions 188.

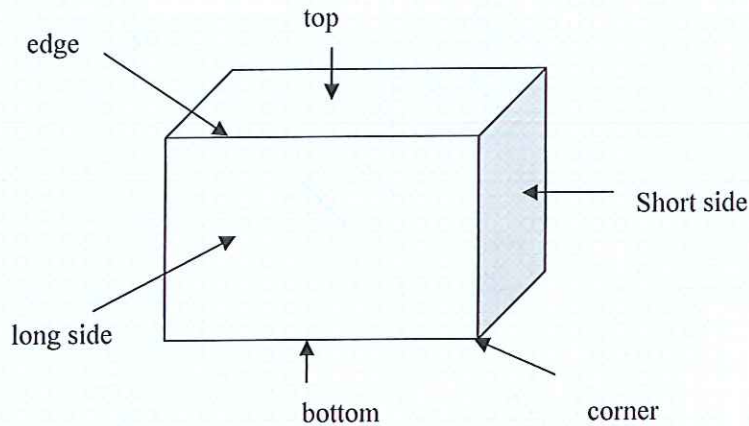

VI. TEST APPARATUS

IE-0279 Drop test system
IE-0178 CNS.TC series electronic counting scale
IE-0766 Steel tapeline

VII. TEST ENVIRONMENT CONDITION

Ambient temperature: (20~25) °C
Ambient humidity: (50%~60%)

VIII. TEST DATA

1.2m Drop test	Side	Edge	Angle
Test Result	a. Without damage to cells or batteries contained therein; b. Without shifting of the contents so as to allow battery to battery (or cell to cell) contact; c. Without release of contents.		
Conclusion	The test package is capable of withstanding a 1.2m drop test in any orientation.		



Pony Testing International Group

Test Item	Gross Weight Measure
Test Result	8.00kg
Conclusion	Passed

IX. PHOTO OF THE SAMPLE

Battery



Package

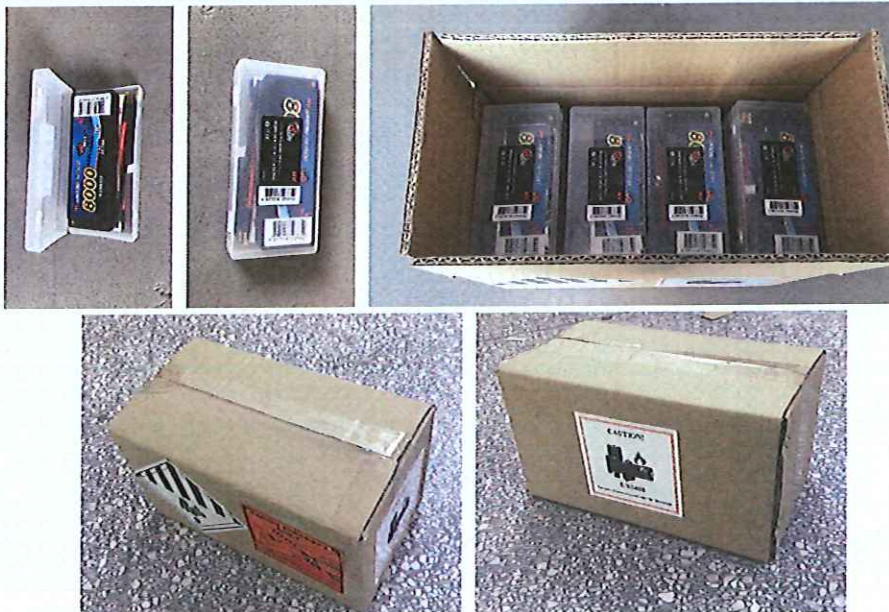

Authenticate the photo on original report only

*** End of report ***